

2 - Hood

CODE	DESCRIPTION
120343	MICRO SWITCH (120364)
150819	CABLE HOLDER PG16 WITH HOLE
160509	FOOT SUPPORT
160530	SPACER OF HANDLE SUPPORT C85-1
160805	GASKET D.8
161110	BACK COVER S90-C85-140
180613	GUIDE F. HOOD C85-140
190607	HANDLE BUSH C30-70
190632	"NYLINER" BUSH
190637	GUIDE FOR DOOR "C"
190638	ROLLER FOR "C" DOOR GUIDE
191013	HINGE F. SUPPORT C30-C70
191014	FLANGE F. HANDLE C30-70
200432	SPONGY RUBBER ADHESIV 8X4 NEOP
200492	SELFADHESIVE GASKET 25X2,5
200497	GASKET FOR DOOR GUIDE C85-C140
210203	RUBBER FOOT 30 MM
250206	GRUB SCREW D.6
260113	STAINL.ST.TE SCREW 8X20 A2 UNI
260219	STAINL.ST TCP SCREW 6X35 A2 UN
260227	M5 X 30 MUSHROOM HEAD SCREW
260228	STAINL.ST SPECIAL SCREW 6X42 3
260530	STAINL.ST WASHER 7X22X2
310212	BLIND NUT M6 BLACK NYLON
330204	SPRING HOOK C95/155-LC380
331016	HANDLE (331026)
341250	HANDLE PIN C85 C140
351227	FRONT PANEL C85
390126	PANEL (390170)
391316	SPRING FOR HANDLE C85/140-G75

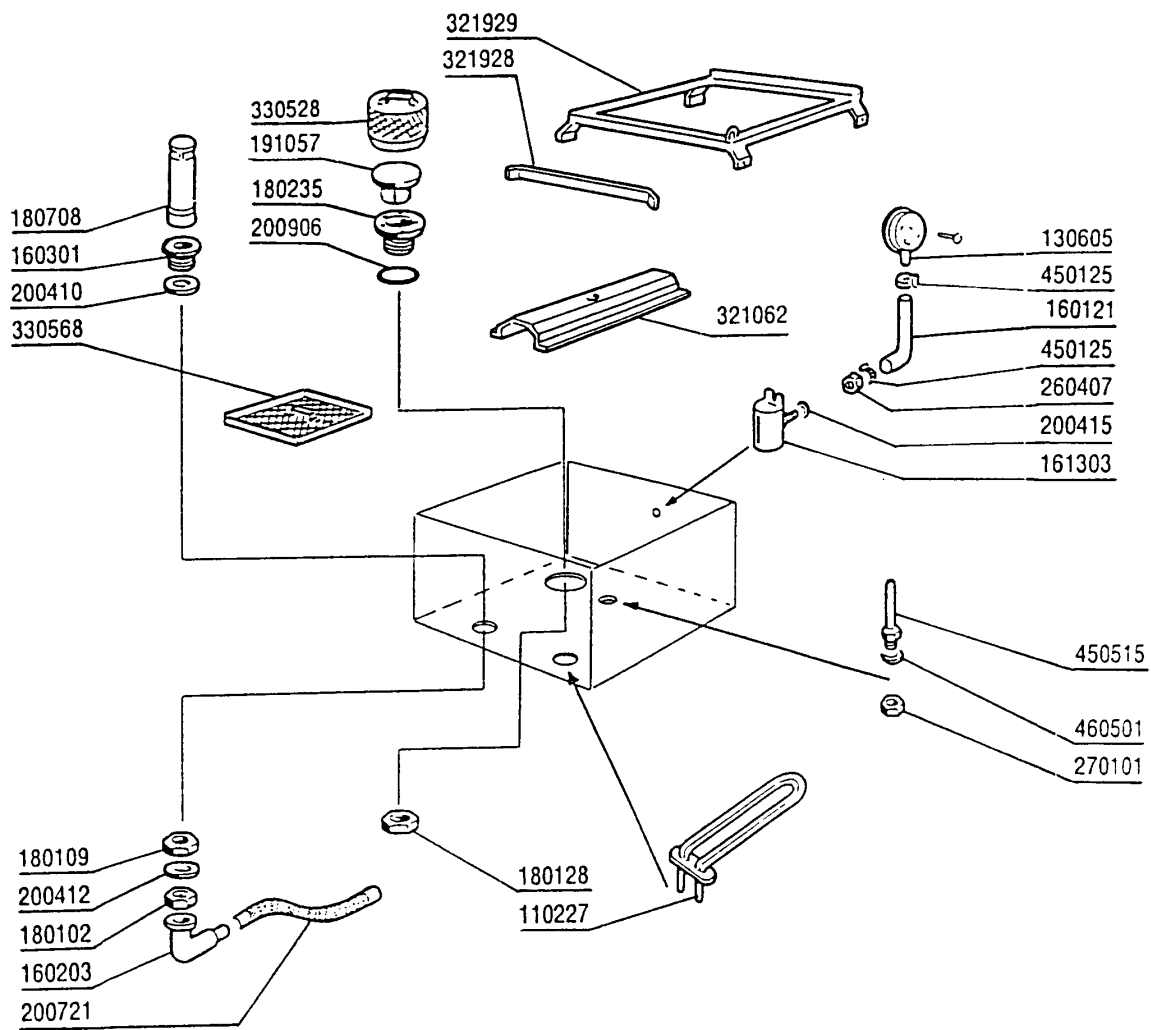

3 - Tank

CODE	DESCRIPTION
110227	HEAT. ELEMENT 3000W 230/400V
130605	PRESSURE SWITCH 50-30 1 LEVEL
160121	HOSE EPDM D. 5 X 9
160203	ELBOW 1"1/2 N-S-F-C /DRAIN
160301	DRAIN OUTLET 1"1/2 C-S-N
161303	AIR TRAP GLASSWASHER
180102	DRAIN PIPE NUT 1"1/2 F45-55
180109	LOCK NUT 1 1/2"
180128	RING NUT 65,4 C140 C85
180235	PUMP SUCTION C85-140
180708	OVERFLOW STANDPIPE H189 C85-14
191057	SUCTION HOSE COVER C85-C140
200410	DRAIN OUTL.WASH.1 1/2"65X47X2
200412	GASKET DRAIN 11/2" 45X33X3
200415	AIR TRAP GASKET -F2 18,5X10X3
200721	DRAIN HOSE 28X35 2MT.
200906	GASKET D.92X66X2
260407	STAINLESS STEEL NUTS D10 UNI 5
270101	HEXAGON LOCK NUT 1/2"
321062	CENTR.CROSS PART F.FILTER SUPP
321928	PLATE F.GUIDE C140
321929	RACK GUIDE C140
330528	STRAINER D.195 SNL C140
330568	FLAT FILTER C85 C140
450125	ELASTIC CLAMP D. 10,4X9,8
450515	STAINL.ST.SHIELD FOR 1 THERMOS
460501	GASKET 24X17X2

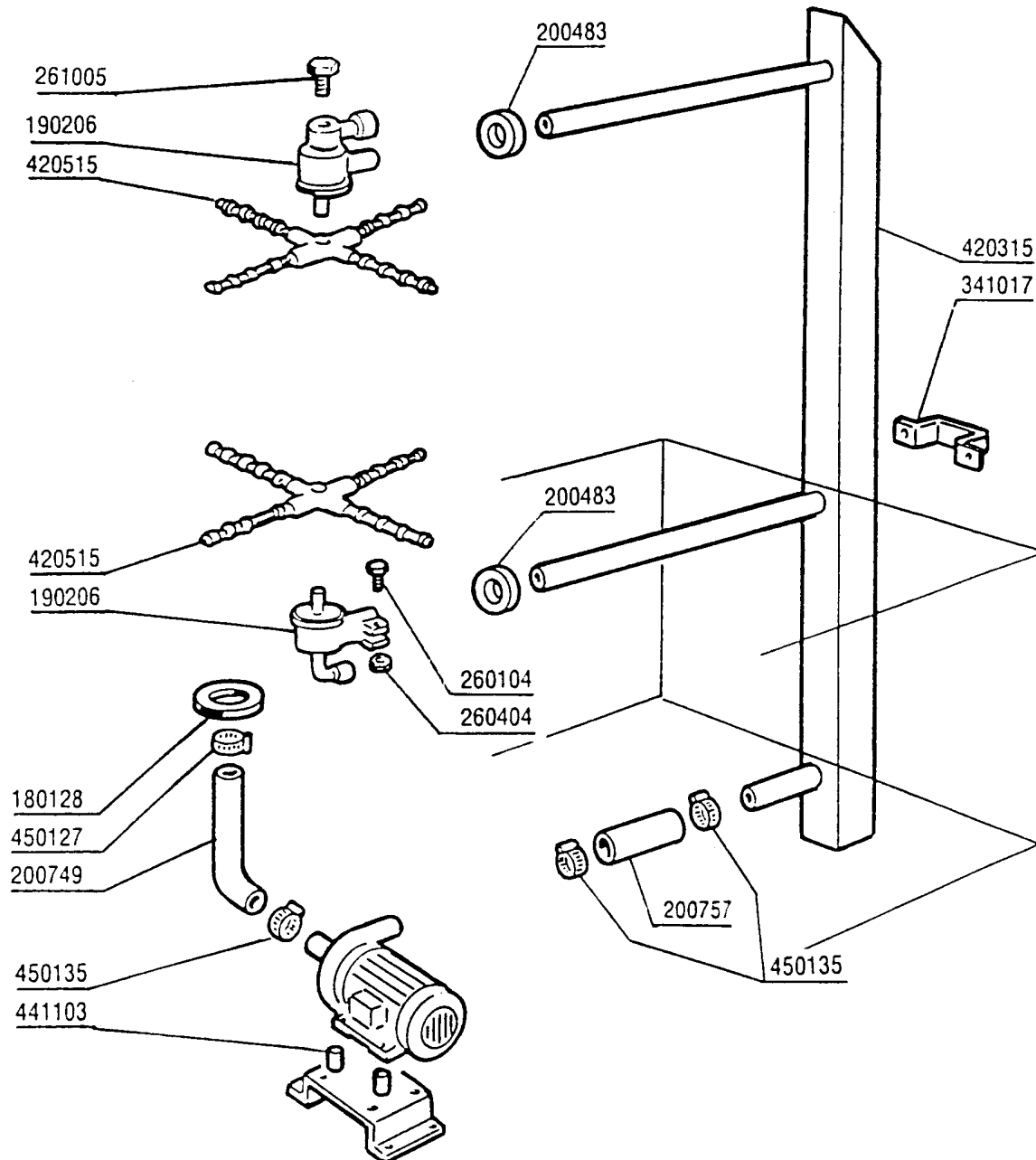

4 - Wash

CODE	DESCRIPTION
180128	RING NUT 65,4 C140 C85
190206	UPPER WASH-RIN ARM SUPPORT C30
200483	GASKET 54X60X25,5X2 C85
200749	SUCTION HOSE C85
200757	DELIVERY HOSE C85
260104	STAINL.ST TE-SCREW A2 6X16 UNI
260404	STAINLESS STEEL NUTS D6 UNI 55
261005	SCREW F. TEE UP. WASH F2-B41
341017	U-BOLT FOR WASH.RAMP C140-C85
420315	WASH COLUMN C85
420515	WASH-RINSE ARM F45-C85
441103	PUMP FEET
450127	CLAMP FE ZN. 68-85 H=12,2
450135	CLAMP FE ZN. 44-56 H=12,2

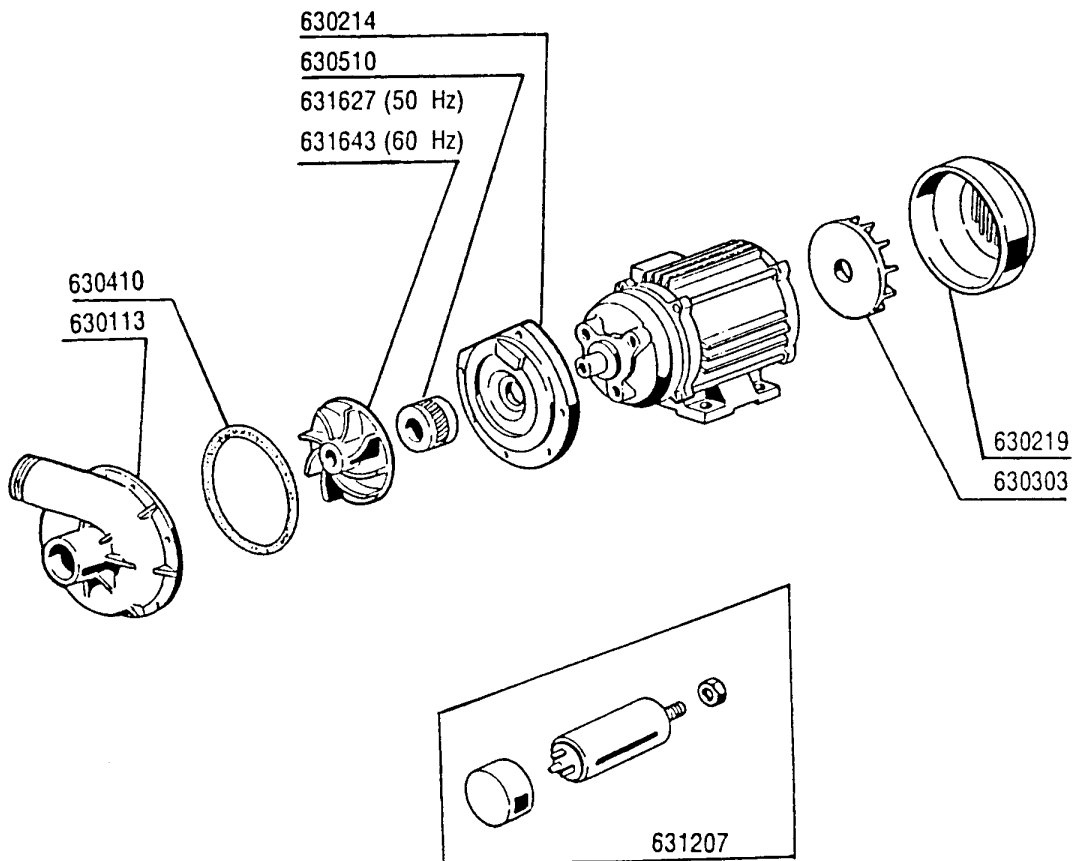
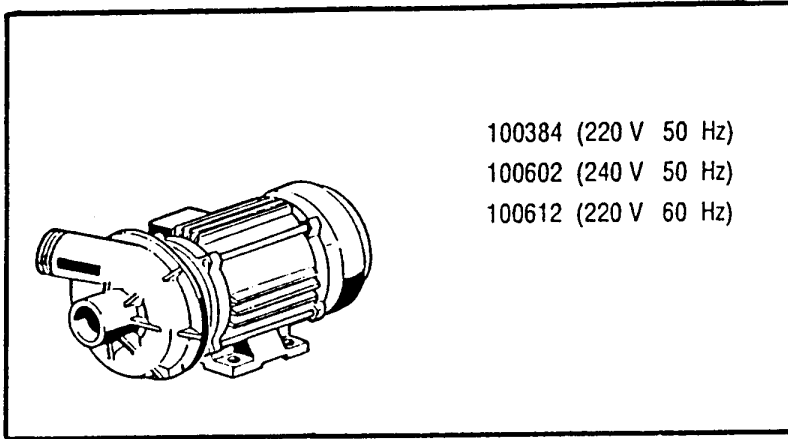

5 - Pump

CODE	DESCRIPTION
100384	PUMP HP 1 240/1-50HZ-1219 1219
100602	PUMP HP 1 240V 50 HZ FI 1219
100612	PUMP HP 1 220/1/60HZ F 1219
630113	VOLUTE FIR HP0,5-1,55
630214	FLANGE PUMP HP0,75-1-1,5
630219	FAN HOUSING FIR HP.0,75-1
630303	FAN IMPELL.OF PUMP HP 0,5-0,7
630410	O-RING PUMP FI HP0,5-0,75-1
630510	PUMP SEAL HP0,5-0,75
631207	CONDENSER 12,5MF. 450V 85C
631627	PUMP IMPELLER FI D103 HP 1-1,5
631643	IMPELLER HP1/1,5 60HZD.90-1219

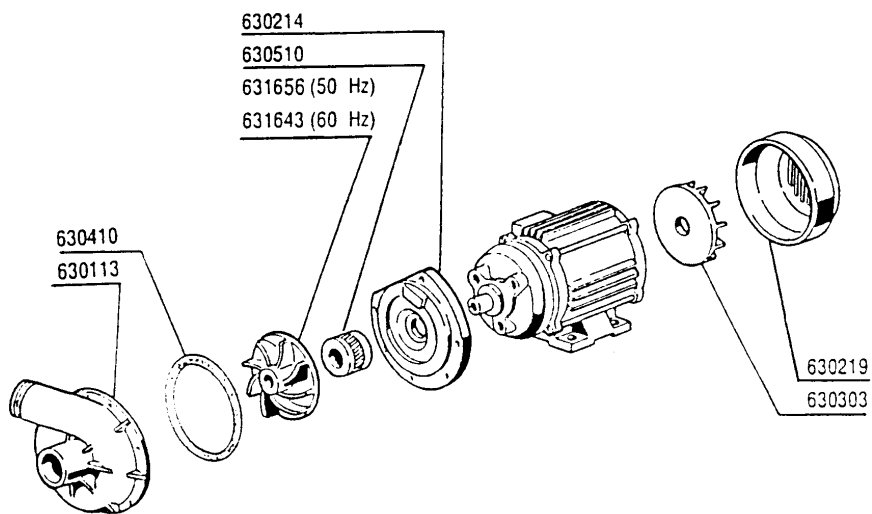
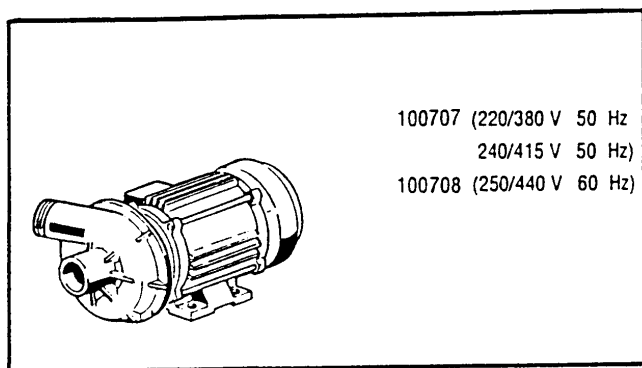

DALLA MATR. 57380
A PARTIR DA LA MATR. 57380
FROM SERIAL NO. 57380
AB SERIENNR. 57380
DESPUES LA MATR. 57380

6 - Pump

CODE	DESCRIPTION
100707	PUMP HP 1,5 220/380/50V-1219
100708	PUMP HP 1,5 255/440-60 1219/1
630113	VOLUTE FIR HP0,5-1,55
630214	FLANGE PUMP HP0,75-1-1,5
630219	FAN HOUSING FIR HP.0,75-1
630303	FAN IMPELL.OF PUMP HP 0,5-0,7
630410	O-RING PUMP FI HP0,5-0,75-1
630510	PUMP SEAL HP0,5-0,75
631643	IMPELLER HP1/1,5 60HZD.90-1219
631656	PUMP IMPELLER 1HP - 2255

7 - Rinse assembly

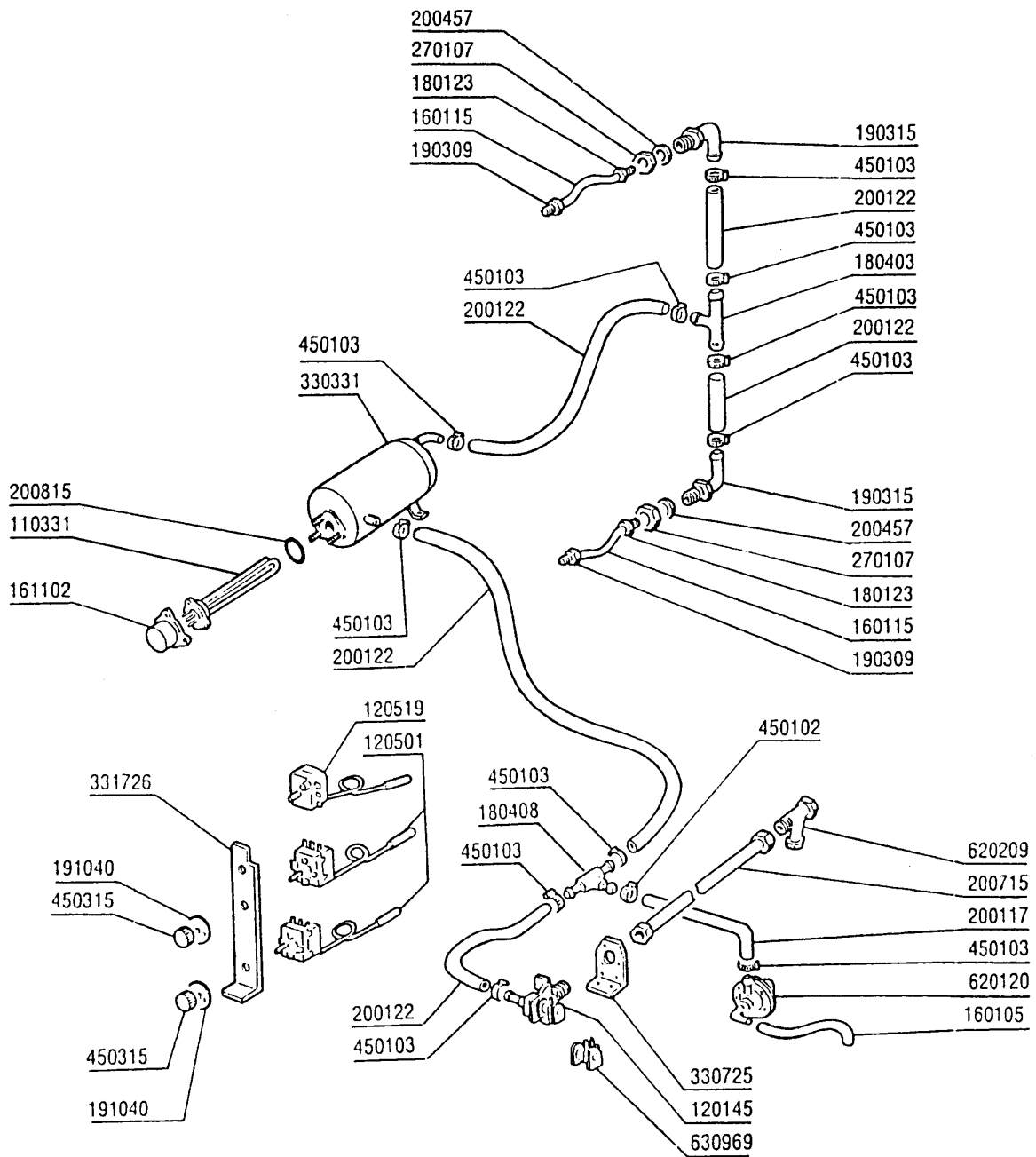

7 - Rinse assembly

CODE	DESCRIPTION
110331	HEAT.ELEMENT 4200W 230/400V
120145	SOLENOID VALVE 12 LT 1 WAY
120501	THERMOSTAT 30/90°C
120519	SECURITY THERMOSTAT 95-125°C
160105	INJECT.INLET HOSE D.6X4
160115	PL.TUBE.D.9.5 B41 (3/8) C30-
161102	ELEMENT COVER MOPL.
180123	CONNECTION NUT / RINSE 5/8 C30
180403	TEE-NIPPLE F2-F300-B10-11
180408	TEE-NIPPLE F.INJECT.W/CENTR.RE
190309	CONNECTION STRAIGHT 3/8" B41 C30
190315	ELL RINSE C30-70
191040	FRAME F.THERMOSTAT KNOB
200117	RUBBER HOSE 7X16
200122	HOSE 11X19
200457	GASKET D.24X16X3 NEOPRENE
200715	HOSE WATER INLET 2M STAINL.ST
200815	O-RING F. HEAT.ELEM.
270107	BRASS LOCK NUT 3/8" FL803
330331	BOOSTER (330342)
330725	STANDARD BRACKET F.SOLEN.VALV
331726	BRACKET FOR 3 THERMOSTATS
450102	CLAMP FE ZN 11-17 H=9
450103	CLAMP FE ZN. 13-20 H=9
450315	KNOB F. THERMOSTAT 90°C
620120	RINSE AID INJECTOR
620209	INLET WATER FILTER
630969	COIL S4216 220/50HZ

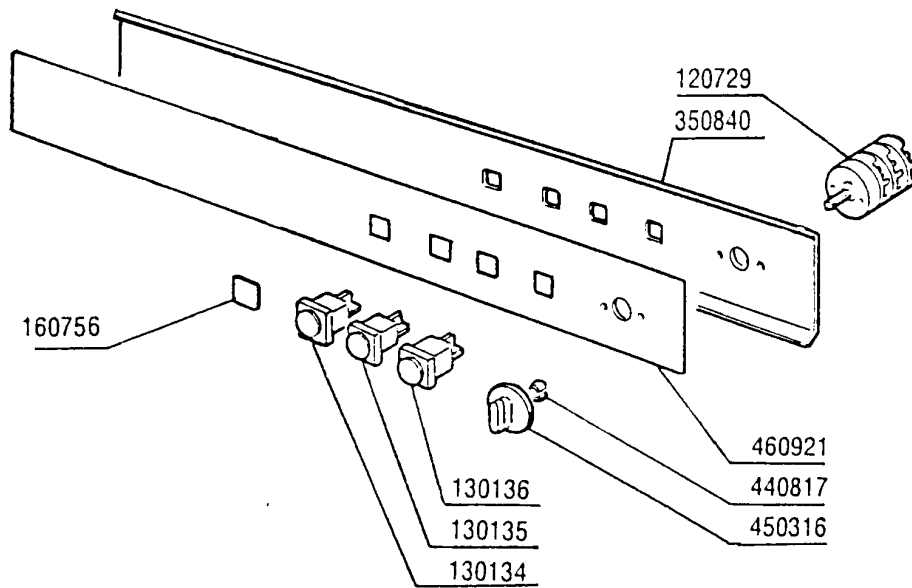
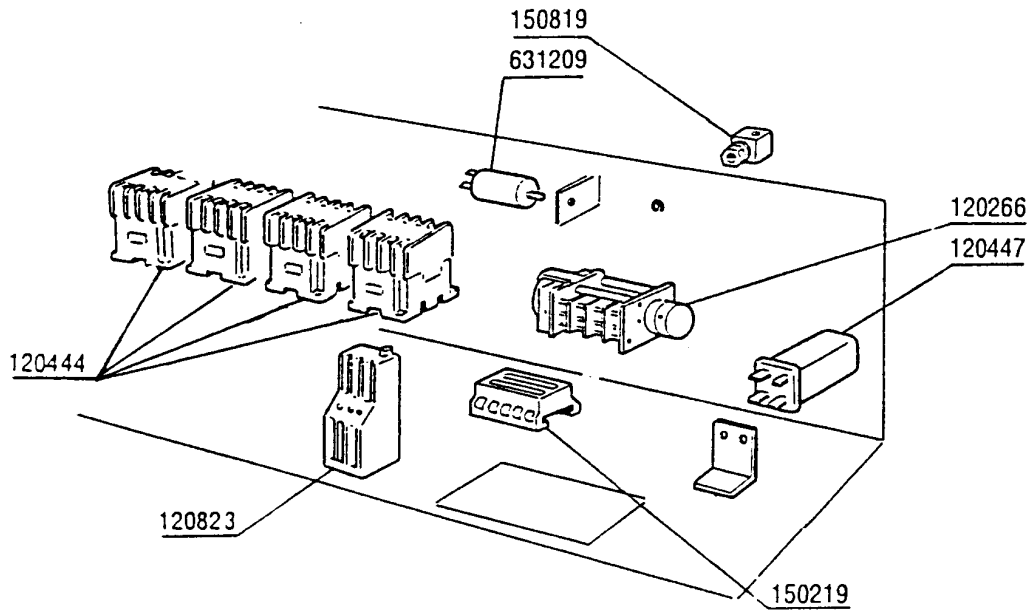

8 - Control Box

CODE	DESCRIPTION
120266	TIMER 6 CAMS 75/120/180"
120444	CONTACTOR 9A 220V 50HZ
120447	AUXIL.RELAY 16A 220V C70-85-14
120729	EIGHT-POLE SWITCH 16A 5 POS.
120823	OVERLOAD RELAY 2.5/4 A
130134	PILOT LAMP 220V
130135	PILOT LAMP: MACHINE READY B10>
130136	PILOT LAMP WORKING MACHINE
150219	TERMINAL BLOCK 5P MMQ165VD26
150819	CABLE HOLDER PG16 WITH HOLE
160756	PLUG WITH SYMBOL C85
350840	PLATE SUPPORT C70-C85-C140
440817	SNAP RING LSCB/1853/17/00
450316	CONTROL KNOB TWO COLOURS B-BT-
460921	PANEL C70-C85-C140
631209	ANTI-NOISE FILTER

9 - Wash arm

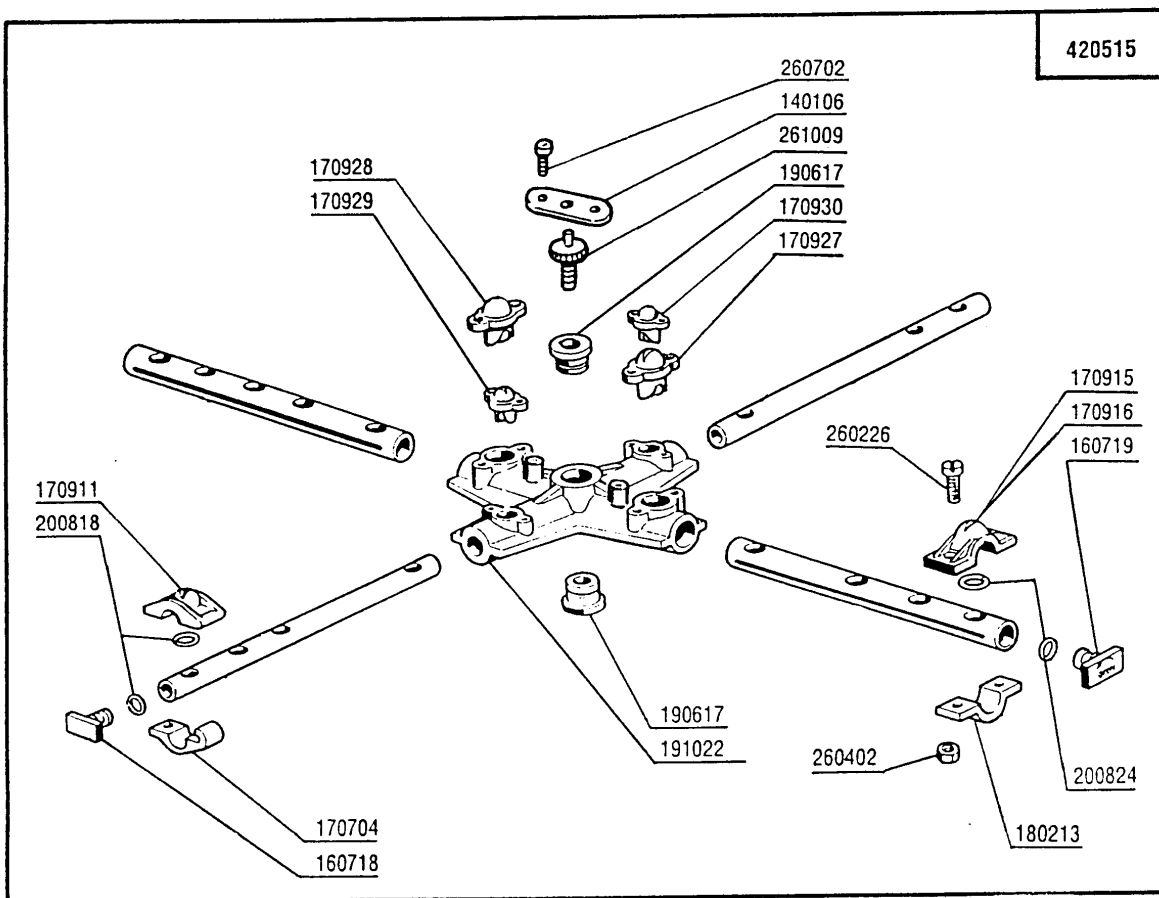

9 - Wash arm

CODE	DESCRIPTION
140106	PLATE F.CLAMP SCREW/WASH-RINSE
160718	PLUG F. RINSE ARM F2-C34M
160719	PLUG FOR WASH ARM D.18
170704	RINSE NOZZLE BOTTOM F-B-C33
170911	RINSE JET B23-F2-C34
170915	RIGHT JET B-F
170916	LEFT JET B-F
170927	WASH JET F2-C-GRAY
170928	IDLE JET F2-C-GRAY
170929	RINSE JET F2-C-GRAY
170930	IDLE JET F2-C-GRAY
180213	FLANGE F.JET LOCKING F2-C34
190617	BUSH
191022	WASH ARM CENTRAL CROSS F-B
200818	O-RING 1,78 X 6,75 X 10,31
200824	O-RING 1,78X12,42X15,98
260226	STAINL.ST TCP SCREW 4X12 A2 UN
260402	STAINLESS STEEL NUT D4 UNI 55
260702	SELF-TAPPING SCREW 4,2X9,5 DIN
261009	RETAIN.SCREW FOR WASH-RINSE AR
420515	WASH-RINSE ARM F45-C85